



PRODUCT DATA SHEET

DGI 02.06.02

| REFERENCE | DESCRIPTION | REV | DATE |
|-----------|--|-----|------------|
| SCGPHP100 | ELECTROLYSIS OF SALT WITH pH For POOL UNTIL 100 m ³ | 0 | 25/11/2019 |

CHARACTERISTICS

EAN13 CODE: 8412081307060

CONTROL BOX SIZE : 19.5 x 13 x 26 cm

CONTROL BOX WEIGHT : 2,760 kg

CHLORINATOR SIZE: Ø 16 x 16 x 34 cm

CHLORINATOR WEIGHT: 1,300 kg

For POOL UNTIL 100 m³ WITHOUT PLUG

Q2 SWC + pH (Gre Salt System pH)

INTEGRATED pH PUMP

CHLORINE PRODUCTION: 21 gr / h



PACKAGING

UNITS: 1

PACKAGING SIZE: 48 x 26 x 34 cm

PACKAGE VOLUME: 0,042 m³

UNIT WEIGHT: 7,720 kg

BOX WEIGT : 0,480 kg

ECOEMBES:

TOTAL CARTÓN: 1046 g

TOTAL PLÁSTICO: 61 g



PALETS

PALET SIZE: 120 X 80 X 15 cm

TOTAL SIZE PALET: 120 X 80 X 151 cm

TOTAL VOLUME: 1,44 m³

4 LAYERS X 6 BOXES

TOTAL PACKAGES PALET: 24

UNITS PALET: 24

TOTAL WEIGHT PALET: 205,280 kg

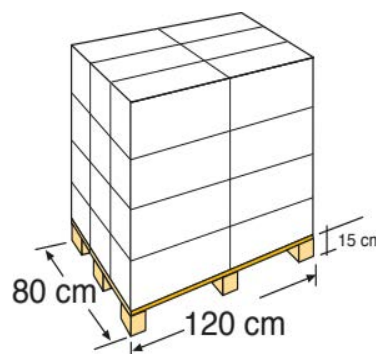

NOTES

FOR ABOVE GROUND AND IN GROUND POOLS

MINIMUN FLOW RATE: 3 m³/h