



# FICHA PRODUCTO/ PRODUCT DATA SHEET

DGI 02.06.02

REF. / SKU

DESCRIPCION / DESCRIPTION

REV

DATE

FIS600

FILTRO ARENA SIN BOMBA / INDEPENDENT TOP BLOW MOLDED FILTER

0

29/5/19

NEW COLLECTION 2020

## CARACTERÍSTICAS / CHARACTERISTICS

CODIGO / EAN13 CODE : 8412081305011

CAUDAL / FLOW RATE: 12 m3/h

MEDIDAS MONTADO / MEASURE: 59 x 59 x 96 cm CR: ? g

SAND CAPACITY: ± 85 kg NO INCLUIDA / NOT INCLUDED

PESO / WEIGHT: 12,500 Kg.

CONEXIONES / CONECTIONS: Ø 32 / 38 mm - 1,5"

CUBA / BLOW MOLDED TANK: Ø 600 mm

VALVULA 6 VIAS / 6 WAYS VALVE

MANÓMETRO INCLUIDO / MANOMETER INCLUDED

BASE DE PLÁSTICO / PLASTIC BASE



## EMBALAJE / PACKAGING

UNIDADES ENVASE / UNITS: 1

MEDIDAS ENVASE / PACKAGE SIZE: 60.5 X 60.5 X 98 cm

VOLUMEN ENVASE / PACKAGE VOLUME: 0,359 m<sup>3</sup>

PESO UNITARIO / UNIT WEIGHT: 16,500 kg

PESO EMBALAJE / BOX PACKAGE WEIGHT: 4,000 kg

ETIQUETA / LABEL

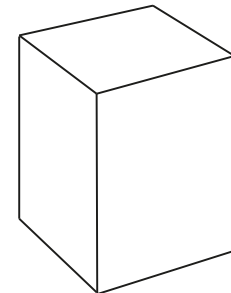

## PALETIZADO / PALETS

MEDIDAS PALET / PALET SIZE: 120 X 100 X 15 cm

MEDIDAS TOTAL PALET / TOTAL SIZE PALET: 120 x 100 x 136 cm

VOLUMEN TOTAL PALET / TOTAL VOLUME: 1,63 m<sup>3</sup>

2 CAJAS POR PLANTA / BOXES X 2 PLANTAS / LAYER

TOTAL EMBALAJES / PACKAGES PALET: 4

TOTAL DE UNIDADES PALET / UNITS PALET: 4

Peso total con palet / Total weight included palet: 90 kg

ETIQUETA IDENTIFICACION PALET / PALET LABEL

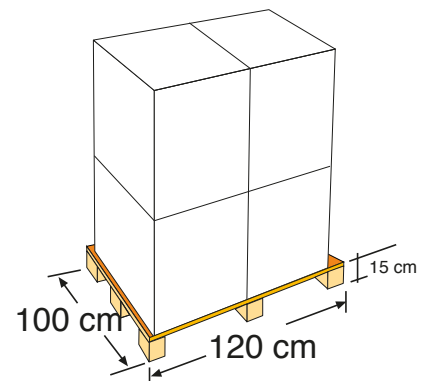

## OBSERVACIONES / OBSERVATIONS

FAMILIA: 160 - SUBFAMILIA: 000

UNIDAD ECOEMB: CARTON: ? g - PLÁSTICO: ? g